

ROTATOR GR-160FD-2

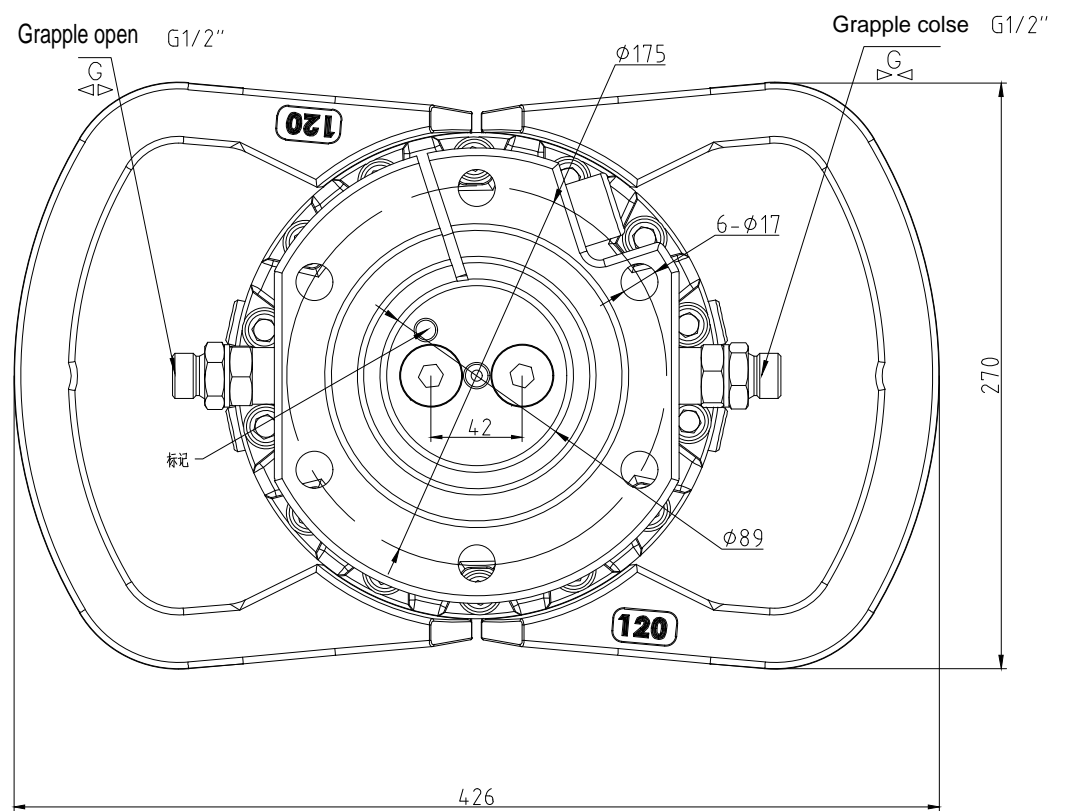
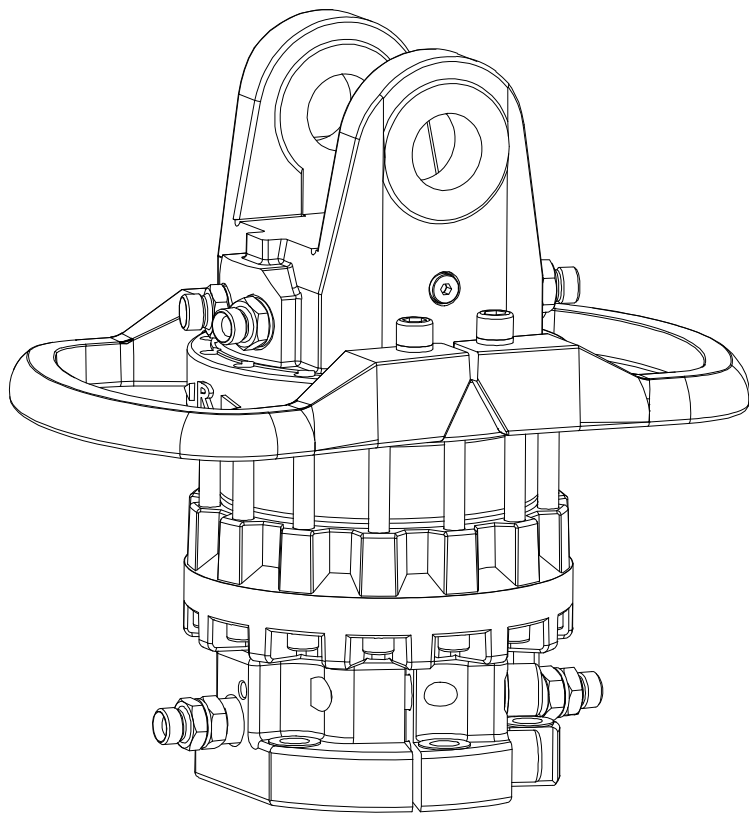
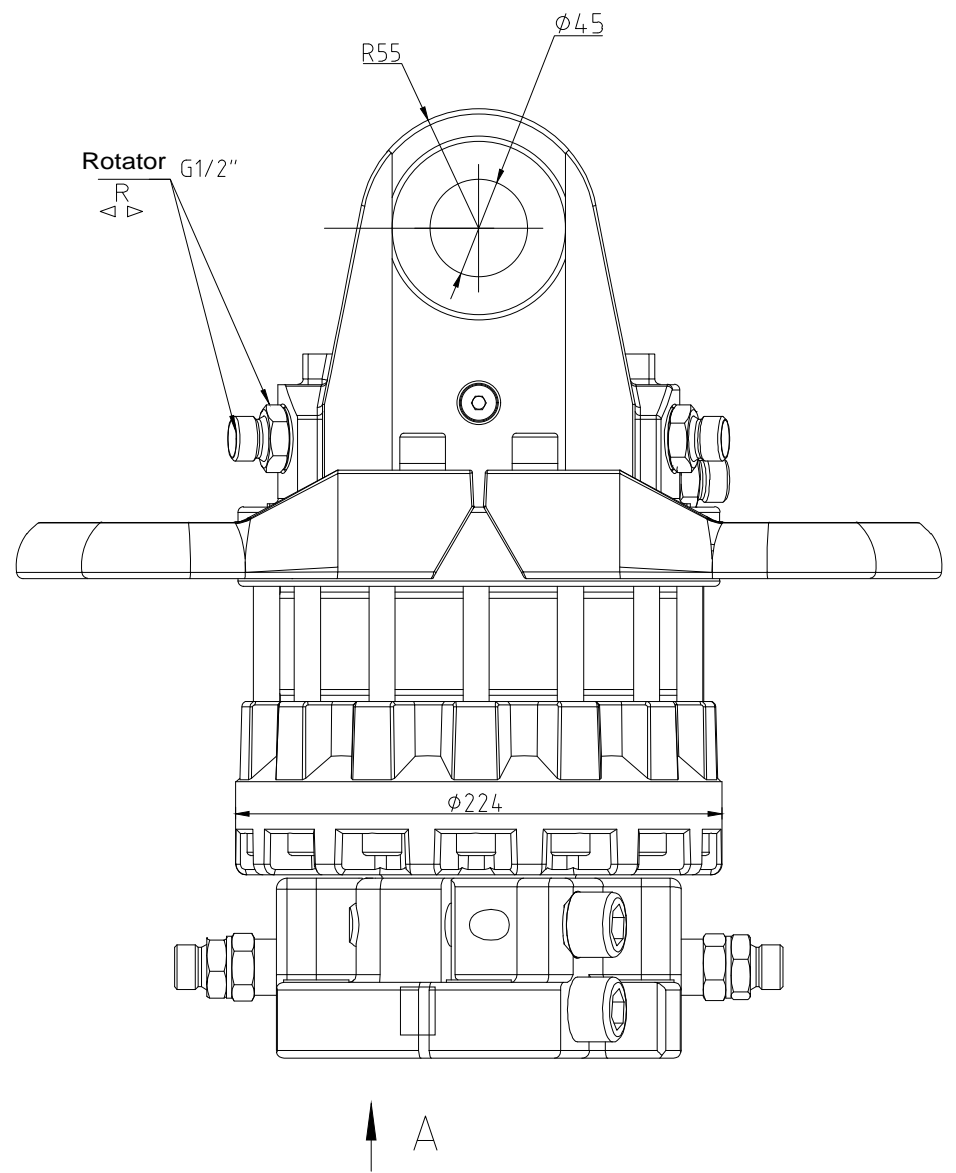
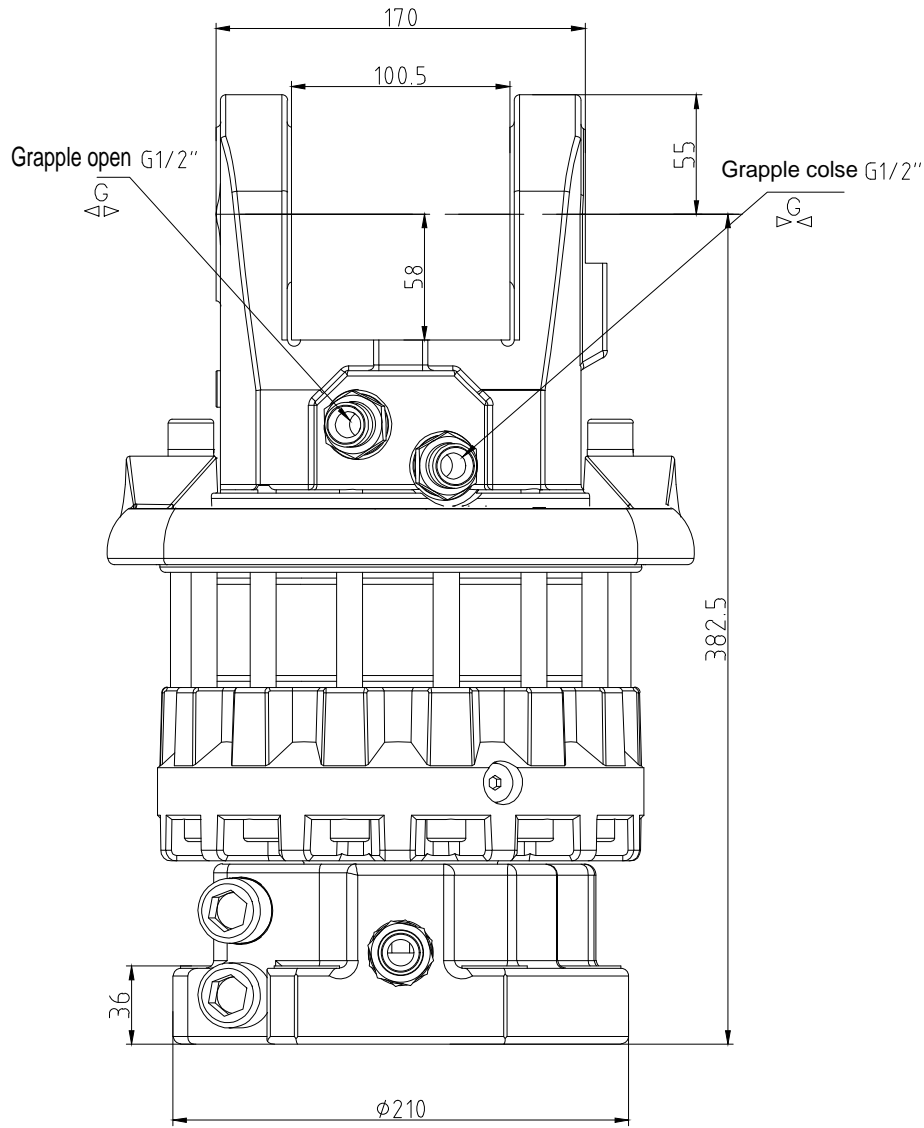

Technical data

Rotation	Unlimited
Max axial load static, KN	+160
	- 100
Max axial load dynamic, KN	+80
	- 50
Torque at 25Mpa, Nm	3100
Rec oilflow, ml/r	1000
Weight, kg	71

Max working pressure:

Rotator	←R→	Max 25 MPa (3625 psi)	G 1/2"
Grapple / Tool open	←G→	Max 30 MPa (4350 psi)	G 1/2"
Grapple / Tool close	→G←	Max 30 MPa (4350 psi)	G 1/2"

Connection:

RIMA

Xibeyu Industry Zone, Laizhou, Shandong, China
 Tel:+(86)-186 6387 9840 Fax:+(86)-535-6805690
 E-mail:info@rimamach.com